

MODEL 7041 FLANGE ADAPTER – ANSI CLASS 125/150

The Model 7041 Flange Adapter allows for a direct connection with ANSI class 125/150 flanges. The specially designed gasket enables the transition from a grooved system to a flanged system or component with this single flange adapter. The two-segment design provides an easy and fast installation. 2” through 12” flange adapters are supplied hinged as a single assembly, while 14” - 24” (Model 7041N) are supplied with two separate segments and a draw kit. All include an EPDM rubber gasket and plated track bolts and nuts. Housing segments are supplied with our standard painted finishes, i.e. orange or RAL3000 red. Optional finishes such as hot dipped zinc galvanized and custom epoxy coatings are available.



Always use factory-supplied bolts and nuts to assemble flange segments. The use of other bolts may cause joint failure. If the factory supplied bolts cannot be used for the component that is being connected consult Shurjoint technical services for further guidance.



Always fasten the bolts to the required torque. Please refer to page 3.

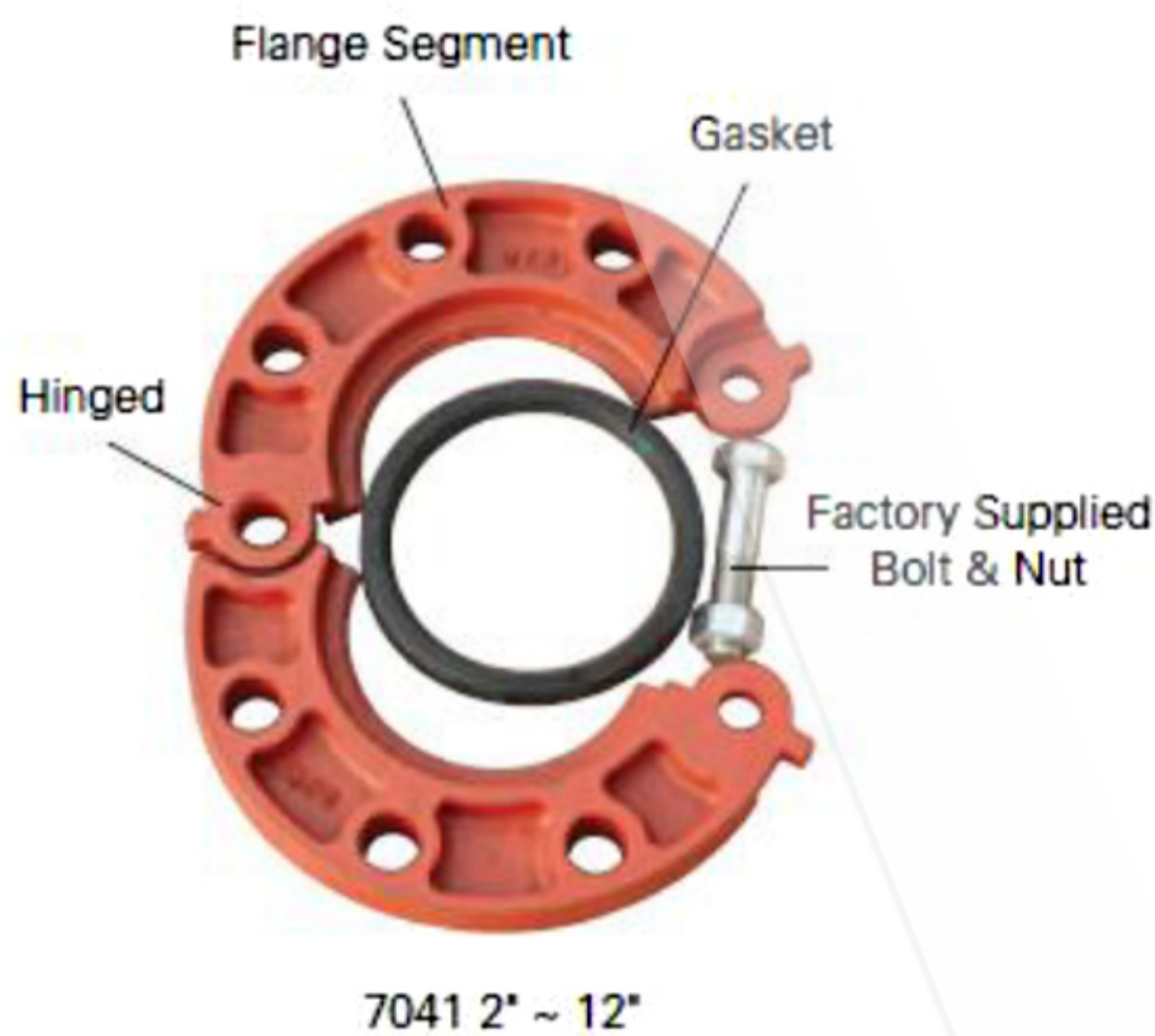

7041 2" ~ 12"

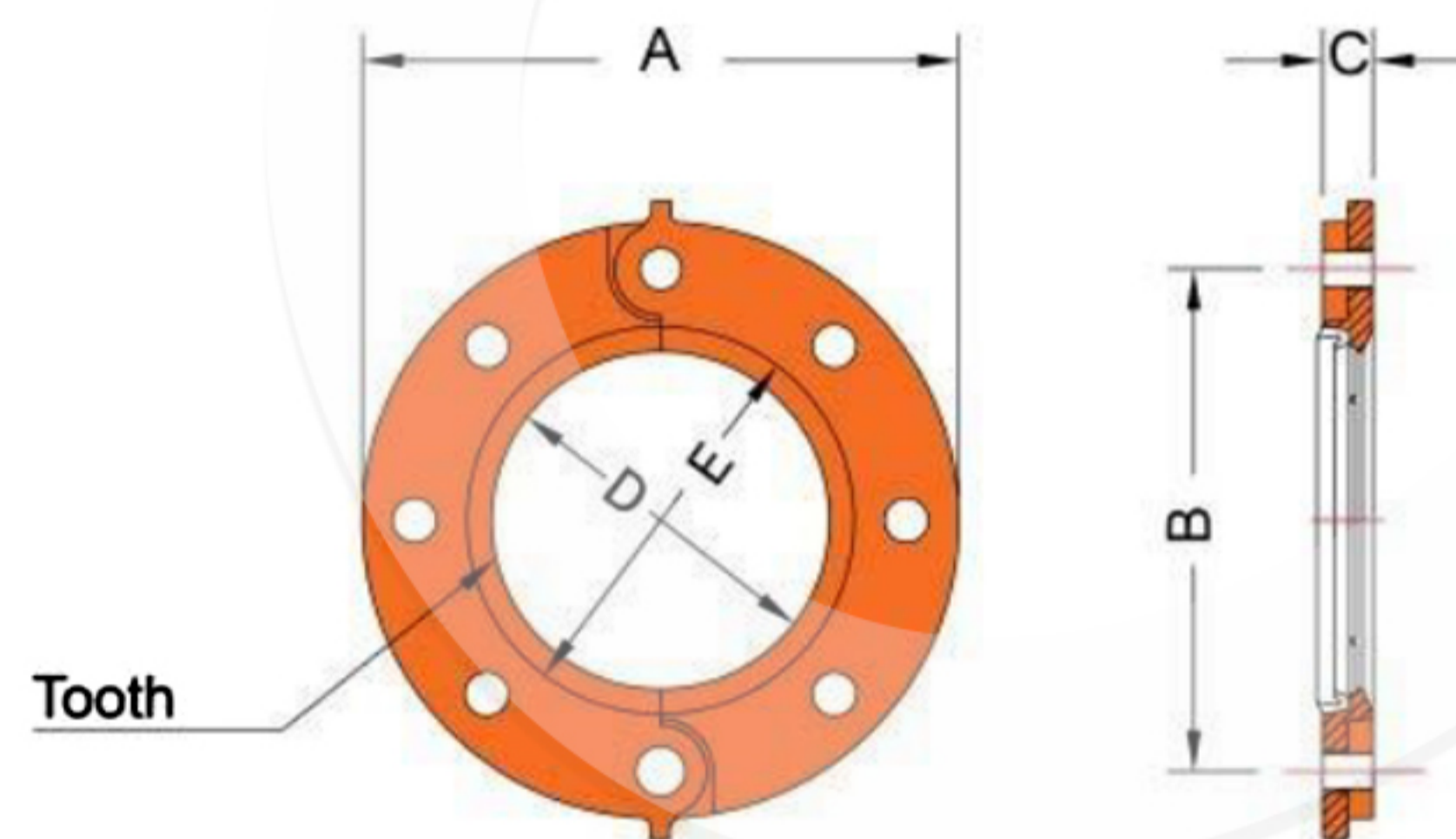

2"~12" (Hinged)

**10
YEAR
LIMITED
WARRANTY**

Full warranty terms can be found on www.shurjoint.com

Model 7041 Flange Adapter - ANSI Class 125/150

Nominal Size	Pipe O.D.	Max. Working Pressure (CWP)*	Max. End Load (CWP)	Dimensions			Sealing Surface		No.	Bolts	
				A	B	C	D	E		Size	Weight
in	in	PSI	Lbs	in	in	in	in	in		in	Lbs
mm	mm	Bar	kN	mm	mm	mm	mm	mm			Kgs
2	2.375	300	1330	6.00	4.75	0.75	2.38	3.07	4	5/8	4.0
50	60.3	20	5.71	152	121	19	60	78			1.8
2½	2.875	300	1950	7.00	5.50	0.87	2.88	3.54	4	5/8	5.1
65	73.0	20	8.37	178	140	22	73	90			2.3
3	3.500	300	2880	7.52	6.00	0.94	3.50	4.17	4	5/8	6.2
80	88.9	20	12.41	191	152	24	89	106			2.8
4	4.500	300	4770	9.00	7.50	0.94	4.50	5.20	8	5/8	8.3
100	114.3	20	20.51	229	191	24	114	132			3.8
5	5.563	300	7290	10.00	8.50	1.00	5.56	6.26	8	¾	10.3
125	141.3	20	31.35	254	216	25	141	159			4.7
6	6.625	300	10340	11.00	9.50	1.00	6.63	7.32	8	¾	11.1
150	168.3	20	44.47	279	241	25	168	186			5.0
8	8.625	300	17520	13.50	11.75	1.14	8.63	9.29	8	¾	17.2
200	219.1	20	75.37	343	298	29	219	236			7.8
10	10.750	300	27210	16.00	14.25	1.18	10.75	11.61	12	7/8	25.7
250	273.0	20	117.01	406	362	30	273	295			11.7
12	12.750	300	38280	19.02	17.00	1.25	12.75	13.62	12	7/8	37.6
300	323.9	20	164.71	483	432	32	324	346			17.1

* Working Pressure is based on roll grooved standard wall carbon steel pipe.

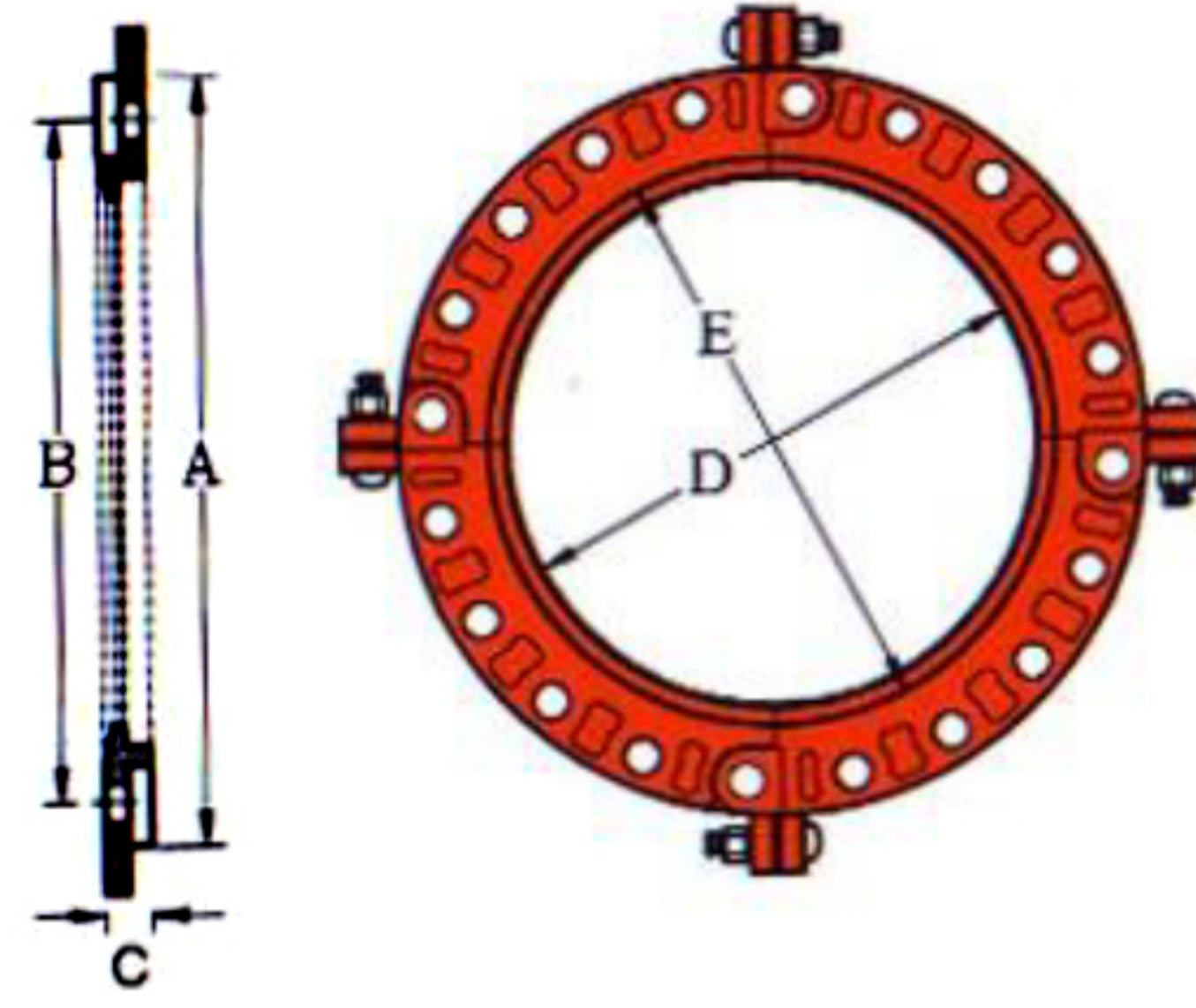

14" ~ 24": 4-segment design

14" ~ 24"

Model 7041 Flange Adapter - ANSI Class 125 / 150

Nominal Size	Pipe O.D.	Max. Working Pressure (CWP)*	Max. End Load (CWP)	Dimensions			Sealing Surface		No.	Bolts Size	Weight
				A	B	C	D	E			
in	in	PSI	Lbs	in	in	in	in	in		in	Lbs
mm	mm	Bar	kN	mm	mm	mm	mm	mm			Kgs
14	14.000	300	46160	21.00	18.75	1.42	14.00	15.08	12	1	61.7
350	355.6	20	198.5	533	476	36	356	383			
16	16.000	300	60290	23.50	21.25	1.42	16.00	16.97	16	1	77.1
400	406.4	20	259.3	597	540	36	406	431			
18	18.000	300	76300	25.00	22.75	1.56	18.00	19.13	16	1 1/8	86.0
450	457.2	20	328.2	635	578	40	457	486			
20	20.000	300	94200	27.50	25.00	1.73	20.00	21.14	20	1 1/8	109.1
500	508.0	20	405.2	699	635	44	508	537			
24	24.000	300	135650	32.00	29.50	1.89	24.00	25.00	20	1 1/4	157.6
600	609.6	20	583.4	813	749	48	610	635			

* Working Pressure is based on roll grooved standard wall carbon steel pipe.



Important Notes:

1. The Model 7041 flange adapter requires a hard flat face for effective sealing. Sealing surface D is the maximum inside face requirement, sealing surface E is the minimum outside face requirement. If the mating flange face is outside these dimensions, a flange gasket and model 49 sandwich plate (Model #49, see cut sheet #V-03) must be used. With the serrated faces of some valves or rubber-faced wafer valves, the mating surface might also be inadequate and a sandwich plate must be used.

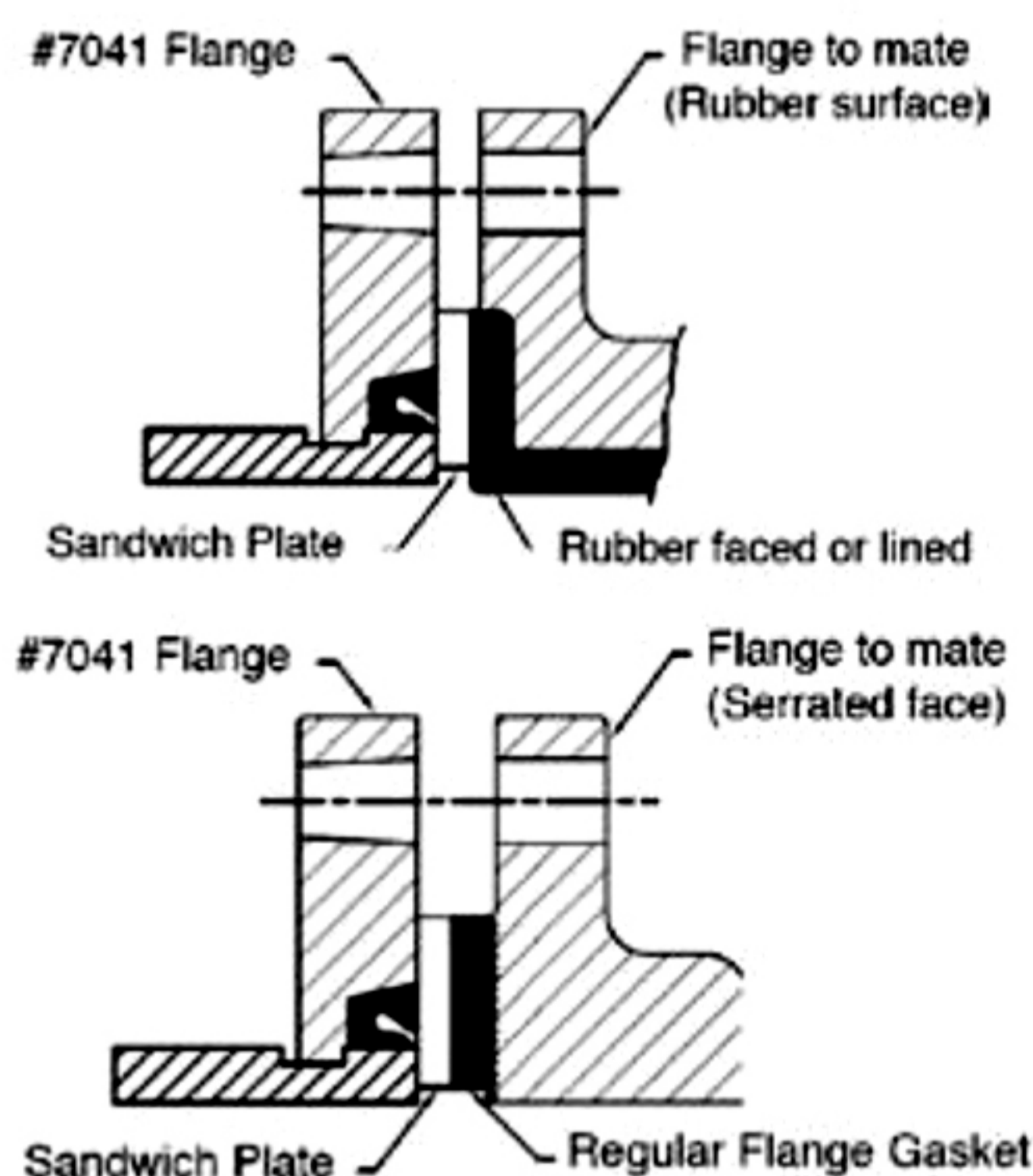

2. The Model 7041 flange adapter has small triangular teeth inside the key shoulder to prevent the pipe from rotating. These teeth should be removed when being connected to schedule 5 pipe, plastic pipe or components or surfaces that could be damaged by these teeth.

3. The Models 7041 flange adapter shall not be used as anchor points for tie-rods across non-restrained joints.

4. When assembling a Model 7041 flange adapter against a butterfly valve or ball valve, make sure that the outside diameter of the flange adapters does not interfere with the valve actuator or the mounting pad of the actuator.

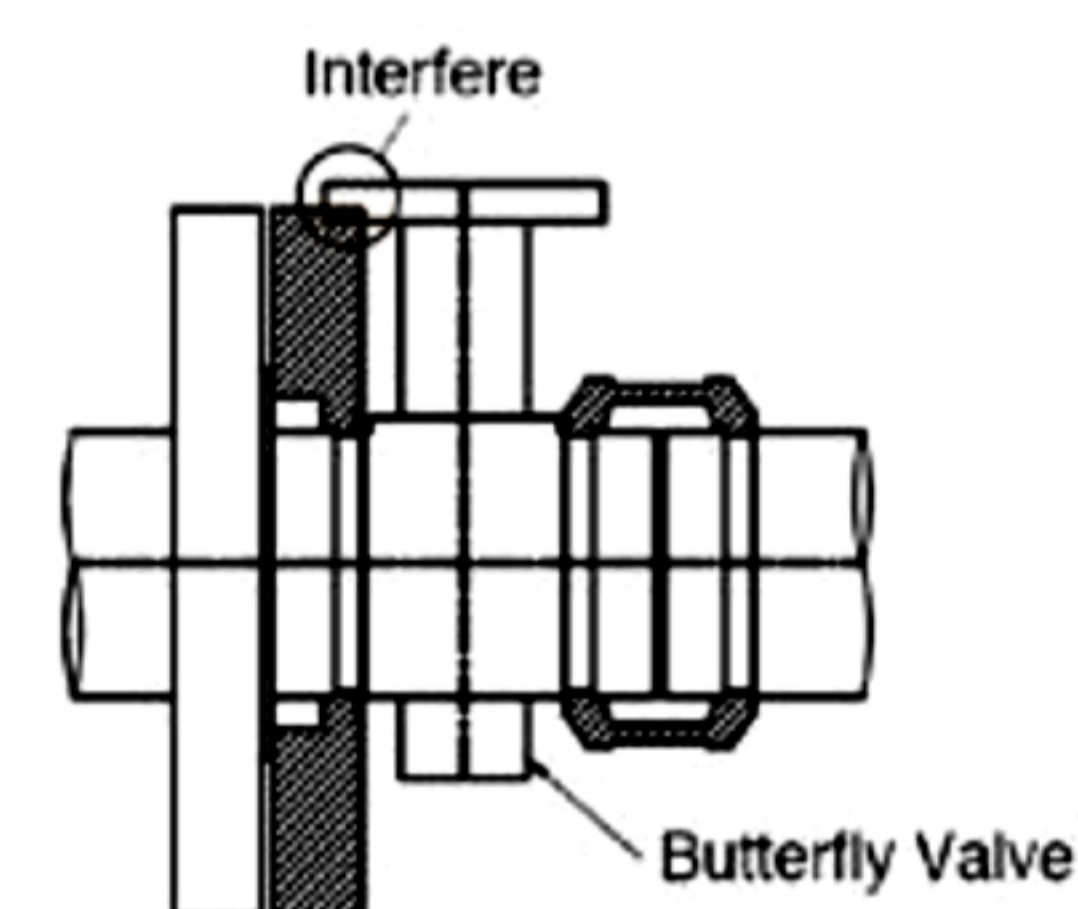

5. Bolt tightening sequence: Like a regular flange joint, it is important to make flange faces contact parallel. Tighten nuts alternately in the sequence of diagonally opposite pairs as shown below until the flange faces meet and make a metal-to-metal contact. When using two model 7041 flange adapters to mate pipe, or wafer / lug valves, the hinge point locations must be staggered 90° to each other, a model 49 sandwich plate must be used where appropriate, and flange adapter segment housings must remain parallel during nut tightening sequence.

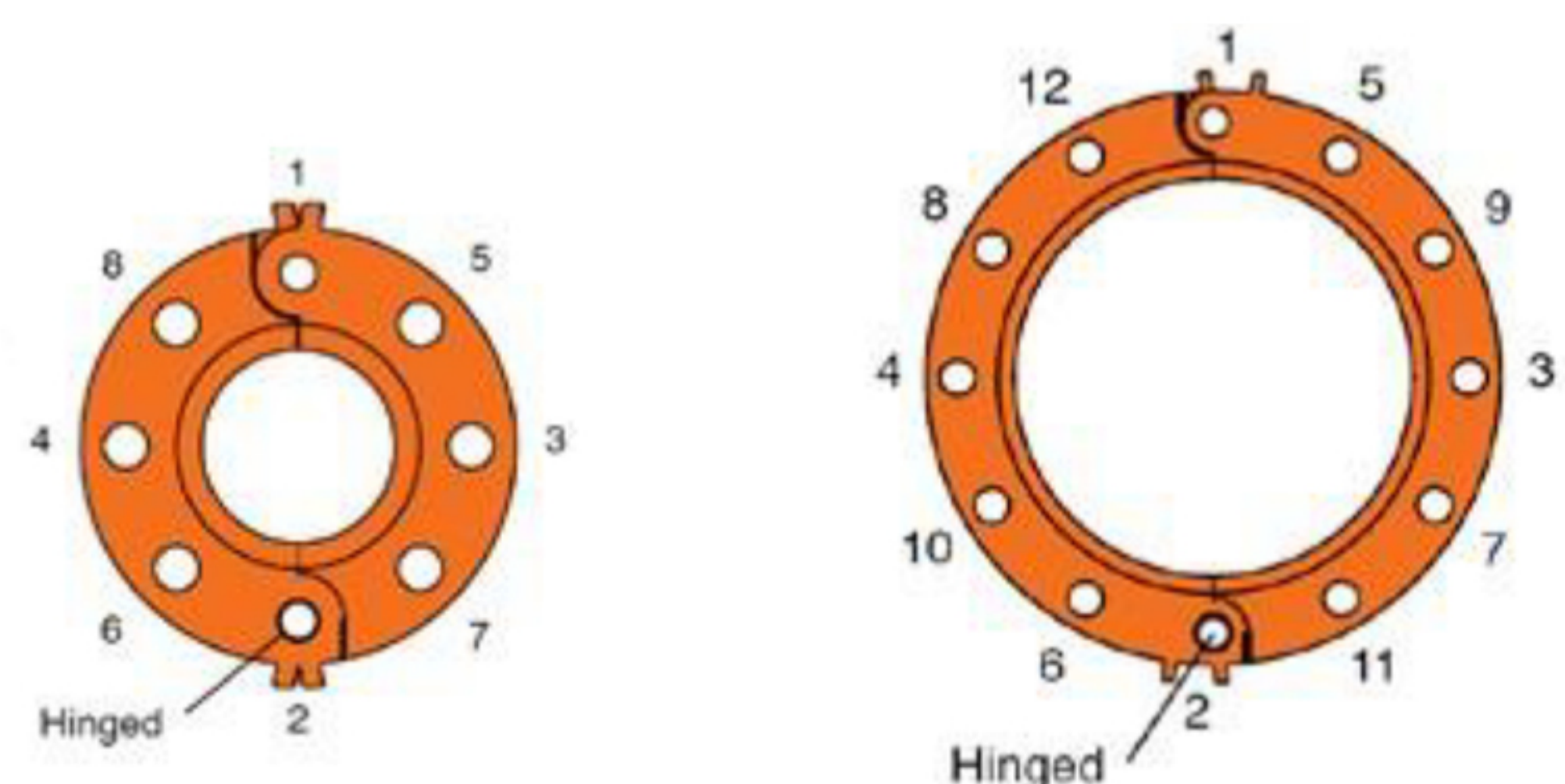

Performance Data

The following tables show the maximum working pressures (CWP) of **Shurjoint** Model 7041 Flange Adapter ANSI Class 125/150 used on both carbon steel and stainless steel pipes. **Shurjoint** ductile iron couplings can be used in conjunction with stainless steel pipe in non-corrosive environment as the flow media does not come in direct contact with the coupling housings but rather only the gasket.

Model 7041 on Carbon Steel Pipe					
Nom. Size in / mm	Cut-Grooved		Roll-Grooved		
	XS PSI / Bar	STD PSI / Bar	STD PSI / Bar	Sch. 10 PSI / Bar	Sch. 7 PSI / Bar
2 50	300 20	300 20	300 20	250 17	250 17
2½ 65	300 20	300 20	300 20	250 17	250 17
3 80	300 20	300 20	300 20	250 17	250 17
4 100	300 20	300 20	300 20	250 17	250 17
5 125	300 20	300 20	300 20	250 17	200 14
6 150	300 20	300 20	300 20	250 17	200 14
8 200	300 20	300 20	300 20	200 14	NR
10 250	300 20	300 20	300 20	200 14	NR
12 300	300 20	300 20	300 20	200 14	NR

Model 7041 on Stainless Steel Pipe					
Nom. Size in / mm	Cut-Grooved		Roll-Grooved		
	Sch. 80S PSI / Bar	Sch. 40S PSI / Bar	Sch. 40S PSI / Bar	Sch. 10S PSI / Bar	Sch. 5S PSI / Bar
2 50	300 20	300 20	275 19	275 19	250 17
2½ 65	300 20	300 20	275 19	275 19	250 17
3 80	300 20	300 20	275 19	275 19	250 17
4 100	300 20	300 20	275 19	275 19	250 17
5 125	300 20	300 20	275 19	200 14	200 14
6 150	300 20	300 20	250 17	200 14	200 14
8 200	300 20	300 20	200 14	75 5	NR
10 250	300 20	300 20	200 14	75 5	NR
12 300	300 20	300 20	200 14	50 3	NR

Note: Hydrostatic shell test: 450 psi (30 Bar) per ANSI B16.5

Required Bolt Torque

The table below provides the standard torque values for proper assembly of **Shurjoint** flange adapters. Use a torque wrench so that all the nuts are tightened equally with a same torque value. **Shurjoint** flange adapters are sealed with elastic (rubber) gaskets, which require much lower torques than those that utilize metallic gaskets.

Model 7041 Flange Adapter - ANSI Class 125 / 150				
Nom. Size in	Bolt		Required Torque	
	No	Size (in)	Lbs-Ft	Nm
2	4	5/8	110 ~ 140	149 ~ 190
2½	4	5/8	110 ~ 140	149 ~ 190
3	4	5/8	110 ~ 140	149 ~ 190
4	8	5/8	110 ~ 140	149 ~ 190
5	8	3/4	220 ~ 250	298 ~ 339
6	8	3/4	220 ~ 250	298 ~ 339
8	8	3/4	220 ~ 250	298 ~ 339
10	12	7/8	320 ~ 400	434 ~ 542
12	12	7/8	320 ~ 400	434 ~ 542
14	12	1	360 ~ 520	488 ~ 705
16	16	1	360 ~ 520	488 ~ 705
18	16	1 1/8	450 ~ 725	610 ~ 982
20	20	1 1/8	450 ~ 725	610 ~ 982
24	20	1 1/4	620 ~ 1000	841 ~ 1356

MATERIAL SPECIFICATIONS

- **Housing:**

Ductile Iron to ASTM A536, Gr. 65-45-12 and or ASTM A395, Gr. 65-45-15, min. tensile strength 65,000 psi (448 MPa).

- **Surface Finish:**

Standard painted finishes in orange or RAL3000 red.

- Hot dip zinc galvanized (Option).
- Epoxy coatings in RAL3000 red or other colors (Option)

- **Rubber Gasket:**

Grade E-pw EPDM (Color code: Double Green stripe) approved under NSF/ANSI 61 and NSF/ANSI 372 for potable water service to +180°F (+82°C). Also good for services for water with acid, water with chlorine or chloramines, deionized water, seawater and waste water, dilute acids, oil-free air and many chemicals.

Not recommended for petroleum oils, minerals oils, solvents and aromatic hydrocarbons.

Maximum Temperature Range: -30°F (-34°C) to +230°F (+110°C)*.

*EPDM seat for water services are not recommended for steam services unless valves or components are accessible for frequent replacement.

- (Option) **Grade "E" EPDM** (Color code: Green stripe) Good for cold & hot water up to +230°F (+110°C). Also good for services for water with acid, water with chlorine, deionized water, seawater and waste water, dilute acids, oil-free air and many chemicals. **Not recommended for petroleum oils, minerals oils, solvents and aromatic hydrocarbons.**

Maximum Temperature Range: -30°F (-34°C) to +230°F (+110°C)*.

*EPDM seat for water services are not recommended for steam services unless valves or components are accessible for frequent replacement.

- (Option) **Grade "T" Nitrile** (Color code: Orange stripe) Recommended for petroleum products, air with oil vapors, vegetable and mineral oils within the specified temperature range. Also good for water services under +150°F (+66°C). Temperature range: -20°F to +180°F (-29°C to +82 °C).

Do not use for HOT WATER above +150°F (+66°C) or HOT DRY AIR above +140°F (+60°C)

- Other options: Grade "O" - Fluoroelastomer.
Grade "L" - Silicone.
For additional details contact **Shurjoint**.

- **Standard Hex Bolts & Nuts:**

Plated hex bolts conforming to ASTM A307 with hex nuts. (2 nuts and bolts are supplied). Bolts and nuts for the flange connection to be supplied by installer.

- **Draw Kit:**

Screw Rod: Carbon Steel.
Assembly holders: Ductile Iron.
Bolts & Nuts: Commercial.



General Notes:

- **Maximum Working Pressure (CWP)** listed is the maximum cold water pressure for general piping services tested to ASTM F 1476 and or AWWA C606 methods. Figures listed are based on roll- or cut-grooved standard wall carbon steel pipe. For other pipe schedules or pipe materials, contact **Shurjoint** for additional information.
- **Max. End Load** is calculated based on the maximum working pressure (CWP).
- **Listed and or Approved Pressures** are pressure ratings for fire protection systems, tested and approved by various approval bodies. Please always refer to the latest approval data posted on the **Shurjoint** website.
- **Field Joint Test:** For one time only the system may be tested hydrostatically at 1½ times the maximum working pressure listed (AWWA C606 5.2.3).
- **Warning:** Piping systems must always be depressurized and drained before attempting disassembly and or removal of any components.
- **The 10 Year Limited Warranty** applies to manufacturing defects only and does not cover severe service/temperature applications or wear parts.
- **Shurjoint** reserves the right to change specifications, designs and or standard without notice and without incurring any obligations.

Shurjoint product specifications in U.S. customary units and metric are approximate and are provided for reference only. For precise measurements, please contact **Shurjoint** Technical Service. **Shurjoint** reserves the right to change or modify product design, construction, specifications, or materials without prior notice and without incurring any obligations to make such changes and modifications on **Shurjoint** products previously subsequently sold.